

## Locational Pricing and Scheduling for an Integrated Energy-Reserve Market

Jie Chen\*  
[jc227@cornell.edu](mailto:jc227@cornell.edu)

James S. Thorp\*  
[jst6@cornell.edu](mailto:jst6@cornell.edu)

Robert J. Thomas\*  
[rjt1@cornell.edu](mailto:rjt1@cornell.edu)

Timothy D. Mount#  
[tdm2@cornell.edu](mailto:tdm2@cornell.edu)

\* *School of Electrical & Computer Engineering, Cornell University*  
 # *Dept. of Applied Economics & Management, Cornell University*

### Abstract

*It is well known that given a network that can become constrained on voltage or real power flows, reserves must also be spatially located in order to handle all credible contingencies. However, to date, there is no credible science-based method for assigning and pricing reserves in this way. Presented in this paper is a new scheduling algorithm incorporating constraints imposed by grid security considerations, which include one base case (intact system) and a list of possible contingencies (line-out, unit-lost, and load-growth) of the system. By following a cost-minimizing co-optimization procedure, both power and reserve are allocated spatially for the combined energy and reserve markets. With the Lagrange multipliers (dual variables) obtained, the scheduling algorithm also reveals the locational shadow prices for the reserve and energy requirements. Unlike other pricing and scheduling methods in use, which are usually ad-hoc and are based on engineering judgment and experience, this proposed formulation is likely to perform better in restructured markets when market power is a potential problem. An illustrative example of a modified IEEE 30-bus system is used to introduce concepts and present results.*

### 1. Introduction

Historically, the term security, when applied to the electric power system, refers to the ability of the bulk system to withstand sudden disturbances such as electric short circuits or unanticipated loss of system components [1]. The static nature of the problem, that is, guaranteeing that in the post-contingency state all power system components are operating within established limits, is tractable once the set of credible contingencies is known. Generally, the most severe contingency is the sudden and unanticipated loss of a large generating unit

although the loss of a critical line or a sudden and large increase in load at strategic locations could be just as catastrophic. The problem of whether or not the system can survive the transition, that is, the dynamic nature of system security, is still a hard and unresolved problem. Since in most systems load is not dispatchable, the security of the system depends on having the proper level, location and type of reserves available when needed to meet a contingency.

In the restructured system, reserves have both an engineering role and an economic role. The engineering role is to ensure that load is met in an environment where there is a regulatory obligation to serve load. The economic role of reserves is to avoid the losses associated with outages. The need for reserves is exacerbated by the fact that load is price inelastic. That is, there is an obligation to serve demand regardless of its level or location. Because of the network and the constraints it imposes, load may be isolated from generation if reserves are not placed properly with respect to a contingency.

All generators have ramp rate constraints that must be taken into account when assigning reserves. These are constraints on how fast a unit can change its output. Generally a unit's ramp rate is about one percent of its capacity per minute. So, if a unit has ramping capability (that is, the ancillary systems necessary to control the unit set-point) and its capacity is 100MW, it can be expected to supply about 10MW per minute. Operating reserves are often classified into four categories: 1) Regulation for Automatic Generation Control (AGC for load following), 2) 10-minute spinning reserve that is usually supplied by generators operating at less than full capacity. A unit with a 4MW/min ramp rate can supply 40MW's of spinning reserves, 3) 10-minute non-spinning reserves that can be supplied by off-line generation that can be started quickly, and 4) 30 to 60-minute non-spinning reserves that can be supplied by off-line generation that can be started and ramped in that time frame. Spinning reserve normally should be no less than one-half the

operating reserves required for each settlement period of the market.

Establishing efficient markets for reserves is an ongoing market design problem. To be effective, reserves must be able to respond to the loads that need them. This paper is about an optimization framework that can be used by a “smart market” in which generators can offer to supply both energy and reserves. Unit commitment based on energy and reserves is an important next step and is not dealt with in this paper. The formulation discussed in this paper does not preclude a treatment of the unit commitment problem. In [2], the problem of finding a profit-maximizing commitment policy of a generating plant that has elected to self-commit in response to exogenous but uncertain energy and reserve price forecasts is addressed.

Since a generator is a multi-commodity device, that is, it can supply energy, reserves and VARs all at the same time, payments should be made for each commodity it provides to the system. Under a restructured system, markets should determine the fair price for each commodity. Currently there are markets for energy, and markets for reserves exist in some form in most currently operating ISO's. Also, a specific form of reserve market is proposed in the Standard Market Design (SMD) NOPR issued recently by the Federal Energy Regulatory Commission (FERC). To guarantee certain system security, most markets are run with deterministic reserve requirements which ensure that the reserve is sufficient to make up for the loss of the largest unit or that the reserve must be a given percentage of forecasted peak demand or some combination of these. Virtually, all assignments are ad-hoc and are based on engineering judgment and experience. We present herein a different way to allocate reserves. It is similar to the way used in [3-4], in which system security is evaluated using probability-weighted performance indices over a set of power-flow cases or a set of contingencies. In this way, the proposed scheduling and pricing algorithm provides locational assignments and locational prices for energy and reserves based on a true co-optimization of both energy and reserves. We call this new co-optimization Responsive Reserves (RR) to distinguish it from the conventional form of Fixed Reserves (FR).

## 2. Joint energy-reserve market structure

The proposed joint energy-reserve market is a one-sided market with no demand-side participation. An Independent System Operator (ISO) deals with the security of the power grid and runs a central auction with price-inelastic load. Suppliers are allowed to submit

separate offers for selling energy and spinning reserves. It is a two-product market, and separate nodal prices are set and paid for energy and reserves respectively. Suppliers take on the responsibility of determining their own tradeoff between the prices and quantities of energy and reserves in the offers they submit. The ISO will clear the market by doing a security-constrained optimization process. It is a single-settlement market-clearing mechanism, balancing the real-time market in which there is uncertainty about the actual pattern of loads and which one of the listed contingencies could occur. The optimization process consists of two stages:

- 1) A co-optimization is performed in stage one to minimize the expected costs of energy and reserves while meeting system load and transmission constraints, and maintaining certain grid security (cover listed credible contingencies). This stage determines the optimum patterns of energy dispatch and reserves.
- 2) Price-setting stage. Nodal energy and reserve prices are set in this stage. The payment will depend on whether the actual real-time system is in the base or in one of specified contingencies.

The two-stage balancing market is described in detail in the following sections.

## 3. Optimization framework

### 3.1. Notation

In this paper the following notation will be used. Additional symbols will be introduced when necessary.

$i$ :	generator index ( $i = 1, 2, \dots, I$ )
$j$ :	bus index ( $j = 1, 2, \dots, J$ )
$l$ :	transmission line index ( $l = 1, 2, \dots, L$ )
$k$ :	contingency index ( $k = 0, 1, \dots, K$ ), 0 indicates the base case (intact system), predefined contingencies otherwise.
$P_{ik}/Q_{ik}$ :	real/reactive power output of generator $i$ in the $k^{\text{th}}$ contingency.
$R_{ik}$ :	spinning reserve carried by generator $i$ in the $k^{\text{th}}$ contingency.
$\theta_{jk}$ :	voltage angle of bus $j$ in the $k^{\text{th}}$ contingency.
$V_{jk}$ :	voltage magnitude of bus $j$ in the $k^{\text{th}}$ contingency.
$S_{lk}$ :	power flow of line $l$ in the $k^{\text{th}}$

$P_i^{\min}, P_i^{\max}$  : minimum and maximum real power capacity for generator  $i$   
 $Q_i^{\min}, Q_i^{\max}$  : minimum and maximum reactive power capacity for generator  $i$   
 $R_i^{\max}$  : maximum reserve for generator  $i$   
 $V_j^{\min}, V_j^{\max}$  : voltage magnitude limits for bus  $j$   
 $S_l^{\max}$  : power flow limit for line  $l$   
 $C_{P_i}(P_{ik})$  : energy cost for operating generator  $i$  at output level  $P_{ik}$  in the  $k^{\text{th}}$  contingency.  
 $C_{R_i}(R_{ik})$  : reserve cost for generator  $i$  carrying  $R_{ik}$  spinning reserve in the  $k^{\text{th}}$  contingency.  
 $p_k$  : the probability of the  $k^{\text{th}}$  contingency

### 3.2. Co-optimization (CO-OPT) formulation

The integrated energy and spinning reserve market consists of: 1) a set of suppliers, submitting offers with reserve ramping and maximum available capacity; 2) fixed system demand (but may vary from period to period) for each trading period; 3) a base-case system - intact system that runs smoothly with no failures; 4) a set of specified contingencies, which may contain line-out, unit failure, or unexpected load growth; 5) a set of probabilities, assigned to the base case and listed contingencies. The ISO requires an optimization procedure to determine the schedules to every supplier. The objective here is to minimize the total expected cost (operating energy cost plus the spinning reserve cost) over the predefined base case and credible contingencies, stated as follows,

$$\min_{P, R} \sum_{k=0}^K p_k \left\{ \sum_{i=1}^I [C_{P_i}(P_{ik}) + C_{R_i}(R_{ik})] \right\} \quad (1)$$

The minimization is subject to network and system constraints enforced by each of the base case and contingencies. These constraints include nodal power balancing constraints,

$$F_{jk}(\theta, V, P, Q) = 0, \quad j = 1, \dots, J \quad k = 0, \dots, K \quad (2)$$

line power flow constraints (detailed formulations for (2) and (3) are referred to [5]),

$$|S_{lk}| \leq S_l^{\max}, \quad l = 1, \dots, L \quad k = 0, \dots, K \quad (3)$$

voltage limits

$$V_j^{\min} \leq V_{jk} \leq V_j^{\max}, \quad j = 1, \dots, J \quad k = 0, \dots, K \quad (4)$$

generation limits

$$P_i^{\min} \leq P_{ik} \leq P_i^{\max} \\ Q_i^{\min} \leq Q_{ik} \leq Q_i^{\max}, \quad i = 1, \dots, I \quad k = 0, \dots, K \quad (5)$$

spinning reserve ramping limits

$$0 \leq R_{ik} \leq R_i^{\max}, \quad i = 1, \dots, I \quad k = 0, \dots, K \quad (6)$$

and unit capacity limits

$$P_{ik} + R_{ik} \leq P_i^{\max}, \quad i = 1, \dots, I \quad k = 0, \dots, K \quad (7)$$

Notice that in (5) ~ (7),  $P_i^{\max}$  and  $R_i^{\max}$  are from the submitted offers, which may be lower than the actual physical limits due to sellers' intentionally withholding of capacity.

The formulation so far can be decoupled into  $K+1$  separate sub-problems (corresponding to specified  $K+1$  systems) unless the concept of *Total Unit Committed Capacity (TUCC)* is introduced to tie them up. The TUCC of unit  $i$  in the  $k^{\text{th}}$  contingency is defined as

$$G_{ik} = P_{ik} + R_{ik}, \quad i = 1, \dots, I \quad k = 0, \dots, K \quad (8)$$

If a contingency such as a line-out or a unit failure occurs, the common remedy will be to fix the problem as soon as possible and bring the power grid back to its normal operation condition (the base case). Hence, units are also expected to return to the base case dispatches (least cost solution) upon the return of the failed component. To make this remedy possible for every listed contingency case, the TUCC required in each of the contingencies should be more than or at least equal to the base case TUCC. Meanwhile since our goal here is minimize the total cost, we want as little capacity committed into the market as possible while still meeting the security criteria. For this purpose, the TUCC for any generator  $i$  is required to be the same over all  $K+1$  cases, that is,

$$G_{ik_1} = G_{ik_2}, \quad i = 1, \dots, I \quad k_1, k_2 = 0, \dots, K \quad (9)$$

From (8) and (9),  $R_{ik}$  can be written as

$$R_{ik} = R_{i0} + P_{i0} - P_{ik}, \quad i = 1, \dots, I \quad k = 1, \dots, K \quad (10)$$

The equality constraints (10) then tie up the whole problem. Meanwhile, in the implementation, we can keep the base case reserve decision variables  $R_{i0}$  ( $i = 1, \dots, I$ ) only and get rid of all other reserve decision variables by substituting the right hand side of (10) for wherever  $R_{ik}$  ( $i = 1, \dots, I; k = 1, \dots, K$ ) is used. By doing so, the problem size can be reduced such that implementation efficiency is improved. However, for the ease of conceptual illustration, we keep all  $R_{ik}$ .

### 3.3. Solution properties

$P_i^{\min}$ ,  $P_i^{\max}$  and  $R_i^{\max}$  are the physical limits for unit  $i$ . They define the outer box (black dotted) in Figure 1, together with the 45-degree line indicating the unit capacity limit constraint,

$$P_i + R_i = P_i^{\max} \quad (11)$$

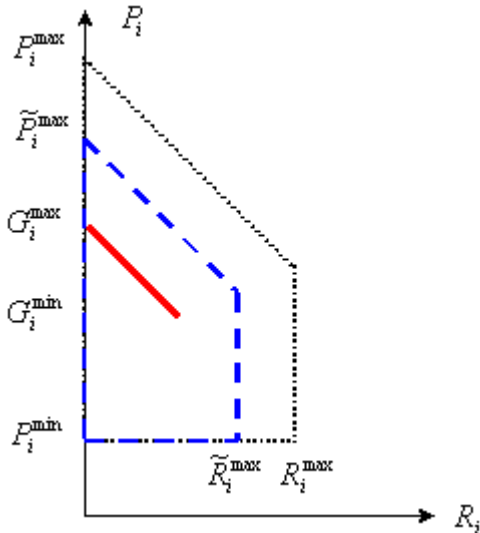


Figure 1. Offer and solution pattern

The region inside the box is the feasible operating region for unit  $i$ . But, usually participating units will make strategic offers by withholding capacity according to real-time market situations. The offered-in limits  $\tilde{P}_i^{\max}$  and  $\tilde{R}_i^{\max}$  ( $P_i^{\min} \leq \tilde{P}_i^{\max} \leq P_i^{\max}$ ,  $0 \leq \tilde{R}_i^{\max} \leq R_i^{\max}$ ) thus define a smaller feasible operating region (inner blue

dashed box), within which the optimal dispatch for unit  $i$  is scheduled.

The co-optimization contains (K+1) Optimal Power Flows(OPFs) only coupled by the reserve costs and the dependence of reserves on generations. Generally the optimal solution is different than (K+1) separate OPF's that do not consider the reserves. Assume the optimal energy dispatch for all K+1 cases, expressed in matrix, is

$$\mathbf{P} = \begin{bmatrix} P_{10} & P_{20} & \dots & P_{I0} \\ P_{11} & P_{21} & \dots & P_{I1} \\ \vdots & \vdots & \vdots & \vdots \\ P_{1K} & P_{2K} & \dots & P_{IK} \end{bmatrix} \quad (12)$$

Likewise, the optimal reserve allocation is

$$\mathbf{R} = \begin{bmatrix} R_{10} & R_{20} & \dots & R_{I0} \\ R_{11} & R_{21} & \dots & R_{I1} \\ \vdots & \vdots & \vdots & \vdots \\ R_{1K} & R_{2K} & \dots & R_{IK} \end{bmatrix} \quad (13)$$

Let

$$\begin{aligned} G_i^{\min} &= \min(P_{i0}, P_{i1}, \dots, P_{iK}) \\ G_i^{\max} &= \max(P_{i0}, P_{i1}, \dots, P_{iK}) \quad i = 1, \dots, I \end{aligned} \quad (14)$$

In the optimal dispatch, for any unit  $i$ , there exists at least one case (out of K+1 cases), its TUCC is consumed as energy only, that is, for that particular case, unit  $i$  does not carry any spinning reserve. That means  $G_i^{\max}$  is unit  $i$ 's TUCC

$$G_{ik} = G_i^{\max}, \quad i = 1, \dots, I \quad k = 0, \dots, K \quad (15)$$

So, by performing the co-optimization, the ISO will assign every participating unit a capacity commitment interval  $[G_i^{\min}, G_i^{\max}]$ .  $G_i^{\min}$  is the minimum energy output required from unit  $i$  for the real-time market, additional energy within that interval may or may not be scheduled according to real-time system situation. The residual committed capacity will still be available and paid as reserves. The actual real-time operating point is thus along the red solid line in Figure 1 and depends on the real-time system condition.

### 3.4. Augmented OPF(AOPF)

CO-OPT determines the optimum energy dispatch and reserve allocation for all the  $K+1$  cases. Since the objective is to minimize the expected costs over all  $K+1$  cases, the obtained energy and reserve shadow prices are also in such an “expected” fashion. However, suppliers would expect to be paid in a real-time fashion, i.e., the payment will depend on the real-time system condition. This requires a single OPF-like optimization to be solved in real-time not only producing the same dispatches as in co-optimization solutions but also revealing spot nodal prices. The Augmented OPF (AOPF), which adds reserves to the traditional OPF, is introduced below to do the job.

The AOPF is defined as the sub-problem of the co-optimization, which is the cost-minimizing optimization for one of the specified  $K+1$  systems (base case or contingencies). The objective for the  $k^{\text{th}}$  AOPF is to minimize the total energy and reserve cost of the  $k^{\text{th}}$  case.

$$f_k = \min_{P, R} \sum_{i=1}^I [C_{P_i}(P_{ik}) + C_{R_i}(R_{ik})] \quad (16)$$

The constraints defined for the  $k^{\text{th}}$  system in (2) ~ (6) still hold, and the only difference is that the generation limits  $(P_i^{\min}, P_i^{\max})$  are replaced by committed capacity limits  $(G_i^{\min}, G_i^{\max})$  carried on from the Stage One co-optimization. In particular, generation limits in (5) are rewritten as

$$G_i^{\min} \leq P_{ik} \leq G_i^{\max} \quad (17)$$

And the available spinning reserve is defined as

$$R_{ik} = G_i^{\max} - P_{ik} \quad (18)$$

The AOPF has the required property as shown by the following proposition.

**Proposition 1** If  $\mathbf{P}$  (12) and  $\mathbf{R}$  (13) are the optimal solutions to the CO-OPT (1), then for any  $k \in \{0, 1, \dots, K\}$ ,  $\bar{P}_k = \mathbf{P}(\mathbf{k}, :)$  and  $\bar{R}_k = \mathbf{R}(\mathbf{k}, :)$  are also the solutions to the  $k^{\text{th}}$  AOPF (16~18).

**Proof.** If not, then there exists at least one  $k$  ( $0 \leq k \leq K$ ), such that  $(\hat{P}_k, \hat{R}_k)$  is the optimal solution to the  $k^{\text{th}}$  AOPF, but  $\hat{P}_k \neq \bar{P}_k$  and  $\hat{R}_k \neq \bar{R}_k$ . Since  $(\hat{P}_k, \hat{R}_k)$  produces lower cost to the  $k^{\text{th}}$  AOPF than  $(\bar{P}_k, \bar{R}_k)$  does, substituting  $(\bar{P}_k, \bar{R}_k)$  with  $(\hat{P}_k, \hat{R}_k)$  in the

optimal solution  $(\mathbf{P}, \mathbf{R})$  to (1) should not only form a feasible solution, but also produce lower total expected cost, contradicting the fact that  $(\mathbf{P}, \mathbf{R})$  is the optimal solution. QED

### 3.5. Real-time pricing

The AOPF therefore will solve for the real-time market. The incremental costs – “the extra cost of producing an extra unit of output”[6] - for energy and reserves are set as nodal energy and reserve prices respectively.

The price definition seems straightforward. And in traditional OPF, actually, the nodal energy prices can be calculated following below steps (assume the energy price at bus  $j$  is what we are after):

- 1) Do the original OPF, record the optimum operating cost as  $f_0$ .
- 2) Perturb the system by adding an extra unit of load at bus  $j$ .
- 3) Do the perturbed OPF, record the minimum post-perturbation operating cost as  $f_1$ .
- 4) The difference of  $f_1 - f_0$  then is the wanted nodal energy price.

Although, in practice, we do not need to perform such perturbations in order to get nodal prices (commonly used optimization algorithms[5] will automatically produce these shadow prices: the dual variables or Lagrange multipliers corresponding to each of the nodal power balancing constraints), the above procedure still can be a very good check and gives clear economic interpretation of nodal prices. Therefore, we try to find out nodal energy and reserve prices for the proposed market in a similar way first. But the perturbation in this case is a bit subtle.

Since we rest on the CO-OPT for the energy and reserve scheduling, the redispatch after perturbation in the AOPF should be consistent with the corresponding perturbed CO-OPT solution. From proposition 1, we know the guarantee here is that both AOPF and CO-OPT have the same unit committed capacity interval for each generator. So, in order to get energy prices, the perturbation has to be done to both CO-OPT and AOPF. In particular, the calculation is performed as follows (assume again we are after the energy price at bus  $j$ ):

- 1) Do the original co-optimization, carrying solved  $[G_i^{\min}, G_i^{\max}]$  for every unit to the real-time

- AOPF; Do the AOPF, record the optimum cost as  $f_0$ .
- 2) Perturb the co-optimization by adding one extra unit of load at bus  $j$  for each of the  $K+1$  systems.
  - 3) Do the perturbed co-optimization, finding out the new interval  $[newG_i^{\min}, newG_i^{\max}]$  for every unit.
  - 4) Perturb the real-time AOPF by adding one extra unit of load at bus  $j$ .
  - 5) Do the perturbed AOPF with  $[newG_i^{\min}, newG_i^{\max}]$  enforced, record the optimum post-perturbation operating cost as  $f_1$ .
  - 6) The difference of  $f_1-f_0$  then is the wanted nodal energy price.

Similar procedure can be used to reveal the nodal reserve prices. Steps 1) ~ 3) are the same as above, but instead of doing perturbed AOPF, we do the unperturbed AOPF but with  $[newG_i^{\min}, newG_i^{\max}]$  enforced such that *the* one extra unit of generation prepared in the CO-OPT stage becomes one extra unit of reserve for bus  $j$  in real-time, thus the cost difference is equal to the nodal reserve price at bus  $j$ .

The numerical perturbation helps understand the economic meaning of nodal prices, however, it is time-consuming. In practice, post-optimization sensitivity analysis can provide a much more efficient way to handle these prices. Assume  $\lambda_j$  is the Lagrange multiplier associated with nodal real power balancing at bus  $j$  from the AOPF;  $\mu_{G_i^{\min}}$  and  $\mu_{G_i^{\max}}$  ( $i=1,2,\dots,I$ ) are the Lagrange multipliers related to the upper and lower boundaries of the unit committed capacity intervals from the AOPF. Define

$$\alpha_{ij} = \frac{\Delta G_i^{\min}}{\Delta D_j} \quad (19)$$

$$\beta_{ij} = \frac{\Delta G_i^{\max}}{\Delta D_j} \quad (20)$$

where  $D_j$  is the real load at bus  $j$ .  $\alpha_{ij}$  is the sensitivity of change of  $G_i^{\min}$  with respect to the change of bus  $j$  load, that is, if there is one unit of load variation at bus  $j$ ,  $\alpha_{ij}$  indicates the corresponding shift of  $G_i^{\min}$ .  $\beta_{ij}$  has similar definition for  $G_i^{\max}$ . The real-time nodal energy price at bus  $j$ ,  $\bar{\lambda}_j$ , then can be calculated as

$$\bar{\lambda}_j = \lambda_j + \sum_{i=1}^I (\alpha_{ij} \mu_{G_i^{\min}} + \beta_{ij} \mu_{G_i^{\max}}), \quad j=1, \dots, J \quad (21)$$

The real-time nodal reserve price at bus  $j$ ,  $\bar{\mu}_j$ , is formulated as

$$\bar{\mu}_j = \sum_{i=1}^I (\alpha_{ij} \mu_{G_i^{\min}} + \beta_{ij} \mu_{G_i^{\max}}), \quad j=1, \dots, J \quad (22)$$

Therefore,

$$\bar{\lambda}_j - \bar{\mu}_j = \lambda_j \quad (23)$$

The interpretation of these calculations can still be put in the context of load perturbation.  $\lambda_j$  will reflect the cost change in the real-time AOPF if the load perturbation is done at bus  $j$ . Since the perturbation is performed in the AOPF without changing  $[G_i^{\min}, G_i^{\max}]$  intervals, one unit of reserve will be called on to cover the load perturbation, that is, one unit of reserve becomes one unit of energy. Therefore, the cost change involves both energy incremental cost and reserve decremental cost. That explains (23). And also recall that the reserve price can be obtained by doing the unperturbed AOPF with  $[newG_i^{\min}, newG_i^{\max}]$ . That means the change of  $[G_i^{\min}, G_i^{\max}]$  actually affects the reserve allocation and hence its price, which is consistent with the formulation of (22). The numerical check of (21) ~ (23) can also be done by the above-described perturbation procedures.

#### 4. Test system

The test system used is a modified IEEE 30-bus system shown in Figure 2. There are six firms in the joint market run by the ISO. Firm 1,2,3 and 4 are located in area 1 while firm 5 and 6 are located in area 2. The transmission capacity between area 1 and area 2 is relatively limited (only 23 MVA in this case) compared to the transmission capacity within the two areas. Each firm owns two generators with a combined maximum capacity of 60 MW. The first generator has a maximum capacity of 40 MW, and the second has that of 20 MW. The two generators of each firm are the same within each area but different between areas. Table 1 lists generator data for firms in both areas. The system is designed so that the tie-lines between areas are usually congested making area 2 a load pocket, in which market power is

easy to explore and excise. Interesting problems, such as the effects of transmission constraints and market power mitigation, therefore can be studied using this test system (But they are beyond the scope of this paper, hence not addressed here).

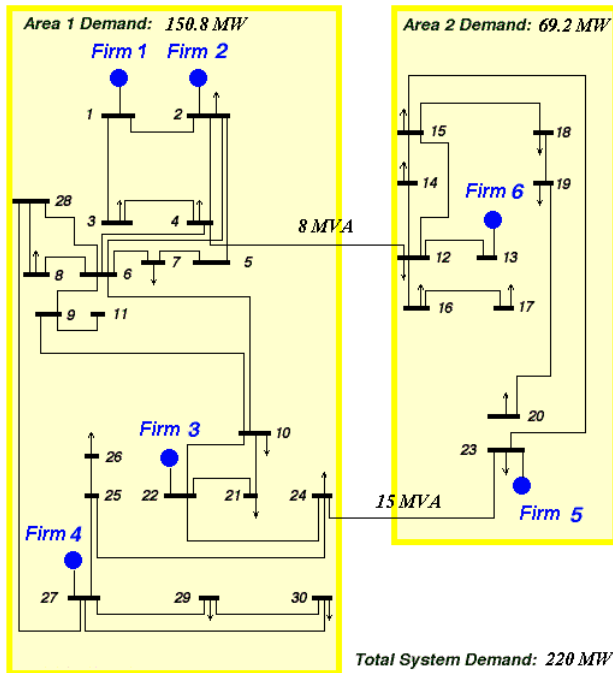


Figure 2. Modified IEEE 30-bus test system

Table 1. Generator data

	Area 1 firms (1,2,3,4)		Area 2 firms (5, 6)	
	Gen #1	Gen #2	Gen #1	Gen #2
$P_i^{\min}$ (MW)	8.0	4.0	8.0	4.0
$P_i^{\max}$ (MW)	40.0	20.0	40.0	20.0
$R_i^{\max}$ (MW)	5.0	10.0	20.0	16.0
Energy Marginal Cost (\$/MW)	20.0	40.0	45.0	55.0

## 5. Numerical results

The market has been experimentally implemented in Matlab. The solutions to the CO-OPT and the AOPF are solved by the Augmented Lagrangian Relaxation approach [7] using a commercial optimization package

MINOS [8] interfaced into Matlab by C.E. Murillo-Sanchez [7]. We refer to this procedure as Responsive Reserves (RR).

The base load of the test market is set to be 220MW with 150.8 MW in area 1 and the rest in area 2, as shown in Figure 2. The load varies proportionally across the network from one trading period to another and is within  $\pm 40$  MW of the base load. Most of the time (80%), the power grid runs smoothly without any failures, which is the designated base case. However, there is a 20% chance that one of the credible contingencies will occur. Six contingencies are considered in this test market, which include 10% unexpected load growth and the failure of the bigger unit (40 MW unit) of all firms except firm 2 (firm 1 and firm 2 are in similar situations, both of them affect the system in a similar fashion, hence only one of them is considered in the contingency list). The six contingencies will occur equally likely. Six firms, each manipulating two units, will submit energy and reserve offers to the market. Although the piecewise-linear offer curve can be decently handled[7], the offer curve is assumed to be linear here for the simple matter. Each unit is only allowed to submit one block and one offer price for energy and reserves respectively.

The first demonstration is the numerical check on the nodal energy and reserve prices by direct computation using (21) and (22). The calculated prices are pretty much consistent with those obtained by the perturbation procedures described in section 3.5. Selected sample results for generator buses are listed in Table 2.

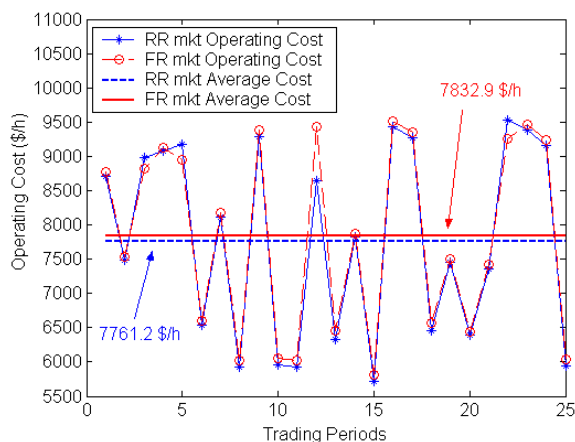
Table 2. Nodal prices by perturbation vs. by direct computation

Nodal price (\$/MWh)	By perturbation		By direct computation	
	Energy	Reserve	Energy	Reserve
Bus 1	42.64	1.88	42.64	1.87
Bus 2	42.12	1.09	42.12	1.08
Bus 22	42.04	1.56	42.04	1.56
Bus 27	42.51	1.52	42.50	1.52
Bus 23	52.97	4.06	52.95	4.02
Bus 13	49.80	4.68	49.80	4.66

Table 3 (on the last page) shows an example market result. The system is in the base case with demand of 231 MW. All of the capacity is offered into the market, i.e., no withholding from the market. The unit number in the first column is used to label different generators such that unit 1 and 2 belong to firm1, unit 3 and 4 belong to firm 2, and so on. According to system load and offers,

expensive units may be decommitted (indicated by '0' in the second column of the table) from the market. In this case, unit 2 and 6 are not chosen for commitment. Basically, because of the transmission limits between two areas, there exists a zonal difference for both energy and reserve prices.

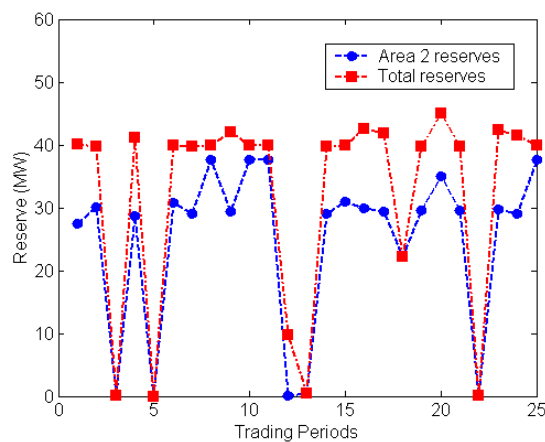
Further tests are performed on comparing the market performance between the proposed RR market and the standard practices used nowadays in the industry (i.e. specifying fixed amounts of reserves in different regions and minimizing the cost of meeting both load and the reserve requirements). This is actually one of the reasons that the RR market is of interest to us. The reserve requirement for the Fixed Reserve (FR) market is set such that the loss of the largest unit can be covered. Due to transmission limits between areas, the regional reserve requirement is forced: 40MW reserves are required inside area 2 and 60MW total are required for the whole system. So that, if the largest unit in area 2 (40MW) is lost, the 40MW reserve inside area 2 is able to cover the contingency; if the largest unit in area 1 (40MW) is lost, presumably, there will be 20MW reserve available in area 1 and another 20MW can be pulled out from the tie-lines (normally the power transferring from area 1 to area 2 congests the tie-lines) to handle the loss of the unit, and 20MW is also needed in area 2 to compensate the missing 20MW coming from the tie lines. The six contingencies for the RR market actually are selected such that both markets can cover the same set of contingencies in order to do fair comparisons (the contingency of unexpected 10% load growth is less severe than the unit-lost contingency, so the inclusion of it will not affect the fairness of the comparison).



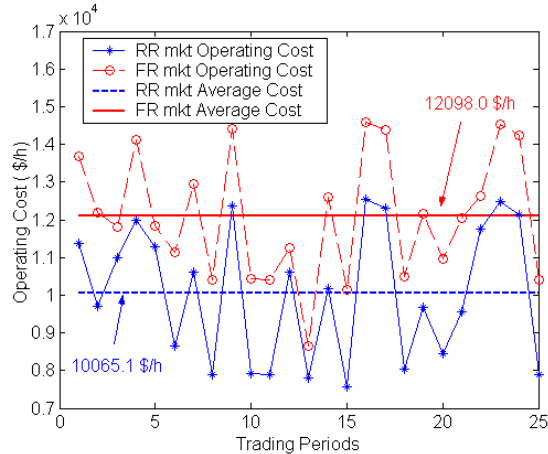
**Figure 3. Comparison of operating costs between two markets (all marginal cost offers)**

Figure 3 compares these two types of markets with all marginal cost offers (\$4/MWh is taken as the marginal cost for reserves). The comparison is done over 25 trading periods with load variation and random contingency (in the contingency list) enforced. Most of the time, the operating cost for the FR market is higher than the RR market. But sometimes, the RR market does cost a little more. The average cost over 25 periods for the RR market is 7761.2\$/h, which is slightly lower than that of the FR market, 7832.9\$/h. The two markets have to meet the same amount of load, while the RR market has more constraints (extra constraints from contingency cases), usually the RR energy solution is a bit expensive than that of the less-constrained FR market. Hence, the reserve assignment gets credits for lowering the total operating cost for the RR market, that is, the “smart” reserve allocation reduces the amount of needed reserves. The statement is verified in Figure 4. The average amount (over 25 periods) of reserves required is 30.8MW in area 2 and 42.5MW in total, which explains the cost saving considering the requirement of 40MW in area 2 and 60 MW in total for the other market.

Notice that area 2 actually is a load pocket, in which firm 5 and 6 possess market power, allowing them to manipulate the market. Figure 5 illustrates how the market manipulation affects the operating costs in both markets. The market outside the load pocket is still assumed to be competitive with everybody submitting marginal cost offers. While inside the load pocket, the two firms are putting very high offers, \$90/MWh for both energy and reserves. The cost difference, 12098.0\$/h in the FR market versus 10065.1\$/h in the RR market, is big.

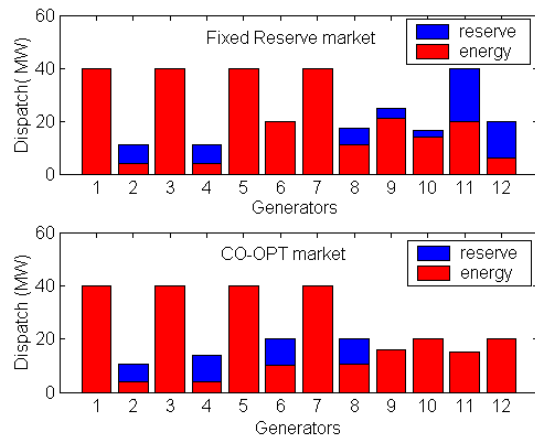


**Figure 4. Reserves required for the RR market**



**Figure 5. Comparison of operating costs between two markets (marginal cost offers for area 1 units, high offers for area 2 units)**

The cost saving is almost 20% in this case, which is a very impressive improvement. Again, the “smart” reserve allocation accounts for the big saving, which is shown in Figure 6. Figure 6 shows the energy dispatches and reserve allocations for each unit in both markets from one of the 25 trading periods. Clearly, in the FR market, due to the deterministic reserve requirement (40MW) inside the load pocket, although firm 5 and 6 make high offers, they can still sell reserves. However, for the RR market, the energy is dispatched so that the reserves are allocated only in the cheap area (area 1), avoiding high reserve charges in area 2.



**Figure 6. Comparison of reserve allocation patterns between two markets (marginal cost offers for area 1 units, high offers for area 2 units)**

## 6. Discussions and conclusions

The RR framework for an integrated energy-reserve market has been introduced in this paper. This underlining optimization procedure provides not only locational assignments but also locational prices for both energy and reserves. Primary tests on the market design have been done based on a modified IEEE 30-bus system. The comparisons between the proposed RR market and the FR market in use show that the “smart way” of locationally assigning energy and reserves in the RR market requires less reserves to maintain the same level of system security as in the FR market, and therefore can improve the market performance – lower the operating cost. Energy and reserves interact more effectively with each other in the RR framework than they do in the FR market. Hence the RR market has the potential advantage of being more difficult to exploit when market power is a potential problem. In an FR market the demand for energy and reserves are both price inelastic.

The unit thermal constraints such as minimum up/down time and start-up costs are ignored for the current-stage development. And also the temporal issues are not honored in this paper. However, the optimization framework and solutions are not necessarily limited by the assumptions made. Solving the unit commitment procedure based on the proposed optimization framework will be an important next step.

The RR framework is introduced here in a one-settlement market set-up. However, the concept can also be applied to other market forms, for example, a two-settlement market. The co-optimization can be used in the day-ahead market to determine the optimum pattern of energy dispatch and reserves to meet the forecasted load and cover specified contingencies. In addition, various forms of day-ahead financial commitments, dependent upon different sets of market rules, can also be included in the co-optimization solutions. It is our intention that the RR framework will improve market performance and achieve better economic efficiency than the existing form of market with fixed requirements for reserves.

## 7. Acknowledgements

This work was supported in part by the US Department of Energy through the Consortium for Electric Reliability Technology Solutions (CERTS) and in part by the National Science Foundation Power Systems Engineering Research Center (PSERC).

## 8. References

- [1] A.A. Fouad, "Dynamic Security Assessment Practices in North America", *IEEE Transactions on Power System*, v 3, n 3, Aug, 1988, p 1310-1321
- [2] R. Rajaraman, L. Kirsch, F.L. Alvarado, and C. Clark, "Optimal Self-Commitment Under Uncertain Energy and Reserve Prices", book chapter in *The Next Generation of Electric Power Unit Commitment Models*, International Series in Operations Research & Management Science, vol.36, Kluwer Academic Publishers, Boston, April, 2001
- [3] Y.Chen, and V. Venkatasubramanian, " Automatic On-line Controller for Coordinated Slow Voltage Control", Accepted by *IEEE Trans. on Power Systems*, ( to appear)
- [4] F.L. Alvarado, et.al, "The Value of Transmission Security," EPRI TR-103634 Research Project 4000-14, Final Report, Aug., 1994
- [5] A. J. Wood, and B.F. Wollenberg, *Power Generation, Operation, and Control*, John Wiley & Sons, Inc., New York, 1996.
- [6] S. Stoft, *Power System Economics: Designing Markets for Electricity*, Wiley-IEEE Press, May, 2002
- [7] C. E. Murillo-Sanchez, R.J. Thomas, "Thermal Unit Commitment With A Nonlinear AC Power Flow Network Model", book chapter in *The Next Generation of Electric Power Unit Commitment Models*, International Series in Operations Research & Management Science, vol.36, Kluwer Academic Publishers, Boston, April, 2001
- [8] B.A. Murtagh, and M.A. Saunders, *MINOS 5.5 User's Guide*, Stanford Univ. Systems Optimization Laboratory Technical Report SOL 83-20R

**Table 3. Example results of the proposed market for one trading period**

Unit	On/Off Status	Energy Dispatch (MW)	Energy Offer (\$/MWh)	Energy Price (\$/MWh)	Reserve Allocated (MW)	Reserve Offer (\$/MWh)	Reserve Price (\$/MWh)
1	1	40.00	21.90	43.48	0.00	0.22	3.88
2	0	-	45.87	43.48	-	0.14	3.88
3	1	40.00	20.58	43.68	0.00	1.56	3.89
4	1	6.69	43.68	43.68	10.00	0.06	3.89
5	1	40.00	26.31	44.94	0.00	1.92	3.63
6	0	-	47.18	44.94	-	3.42	3.63
7	1	40.00	26.83	44.31	0.00	0.46	3.64
8	1	13.35	40.84	44.31	6.65	0.18	3.64
9	1	27.75	49.54	50.04	4.58	3.06	3.06
10	1	4.00	59.42	59.42	0.69	3.04	3.06
11	1	20.00	48.53	50.74	20.00	0.08	2.46
12	1	4.00	56.54	56.54	16.00	0.08	2.46